

DATA SHEET NOTICE BOARDS SB112 40-112

SB1 notice board, 550 x 370 x 40 mm in size (DIN A3 format), comprising: magnetic base in galvanised sheet metal covered in PVC for fixing notices; special aluminium profile with rounded edges; hinged door in transparent Plexiglas (3 mm thick). The notice board is equipped with a security cylinder lock with two numbered keys and 8 magnets for fixing documents.

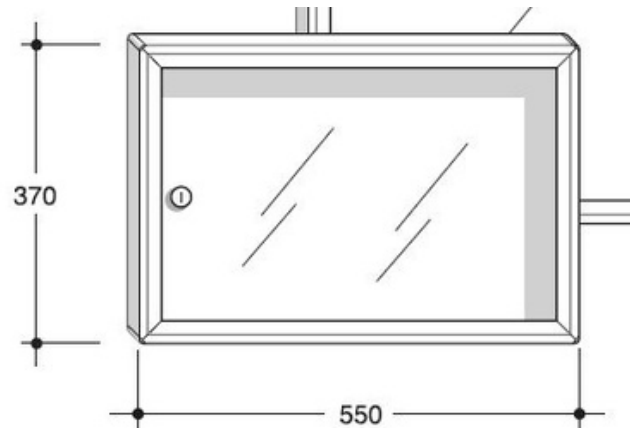

AVAILABLE CODES



Cod. 40-112.54

bronze-gold aluminium with green back panel



Cod. 40-112.9006

wrinkled silver aluminium RAL 9006 with silver back panel

REPLACEMENTS



Cod. 90-020

Chrome-plated lock with safety cylinder and 2 numbered keys (sheet metal hole diam. 15). Duplicable key (numbering only 464)

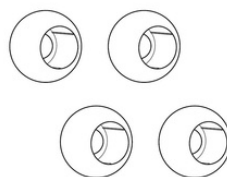

Cod. 40-904

Green magnets for attaching notices
(4 pieces pack)

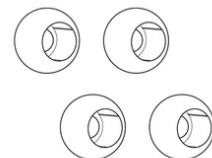

Cod. 40-906

Silver magnets for attaching notices
(4 pieces pack)